

CHAPTER VI.

ALTERATION OF MECHANISMS. CLOSURE.

54. Expansion of Elements.—Certain examples have already shown the reader how widely the external forms of the links in a kinematic chain may be varied, while they still retain exactly the same relative motion (see Figs. 83 and 84, in which both mechanisms are the same inversion of the same chain).

We have now to consider further certain cases in which links of mechanisms are enlarged, reduced, changed in form, added, or omitted, without altering the relative movements of other links.

Perhaps the most familiar instance of a change in form, which in this case is really the *expansion of an element*, is to be found in the eccentric so generally employed for obtaining a reciprocating from a rotary movement in valve-gears and elsewhere, and shown in Fig. 97.

Let us suppose in a slider-crank chain that while the centres of the links remain the same, the radius of the cylindrical surface of the turning pair ab is increased, as in Fig. 107, until at length the crank becomes a disc, inside of which lies the centre of the pair ad .

The crank a has now taken the form of an eccentric, without in any way changing the relative motion of the links, the only alteration being that one element formed on each of the links a and b has been expanded.

Again, take the case already mentioned (in § 34) where in the quadric crank-chain a swinging link c has appar-

ently been replaced by a sliding block travelling in a curved slot, as shown in Fig. 6ob. Notice that the pair bc remains just as before, while the appearance of the chain (but not the relative motion of its links) has been changed simply by

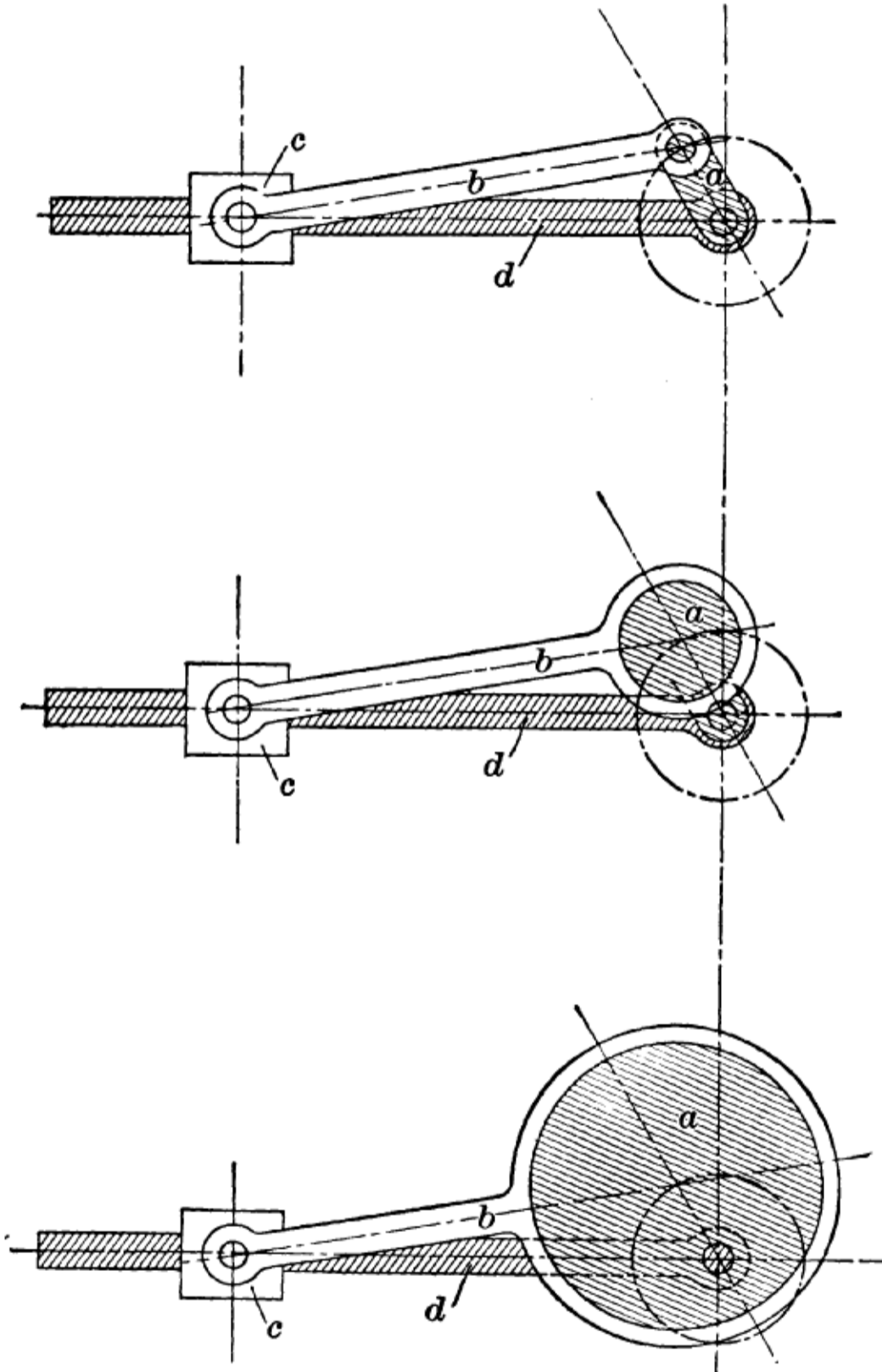

FIG. 107.

increasing the radius of the turning pair cd , and utilizing only a portion of its curved surface. The effective or kinematic length of the link c remains unaltered.

As a third example, imagine the radius of the pair bc ,

in the slider-crank chain of Fig. 108, to be increased as shown, until it is greater than the length of the link b , while the link a retains its original form, that of a crank. The expansion may be carried a stage farther, as shown in Fig. 109, by increasing the radius of the pair ab also, but in a

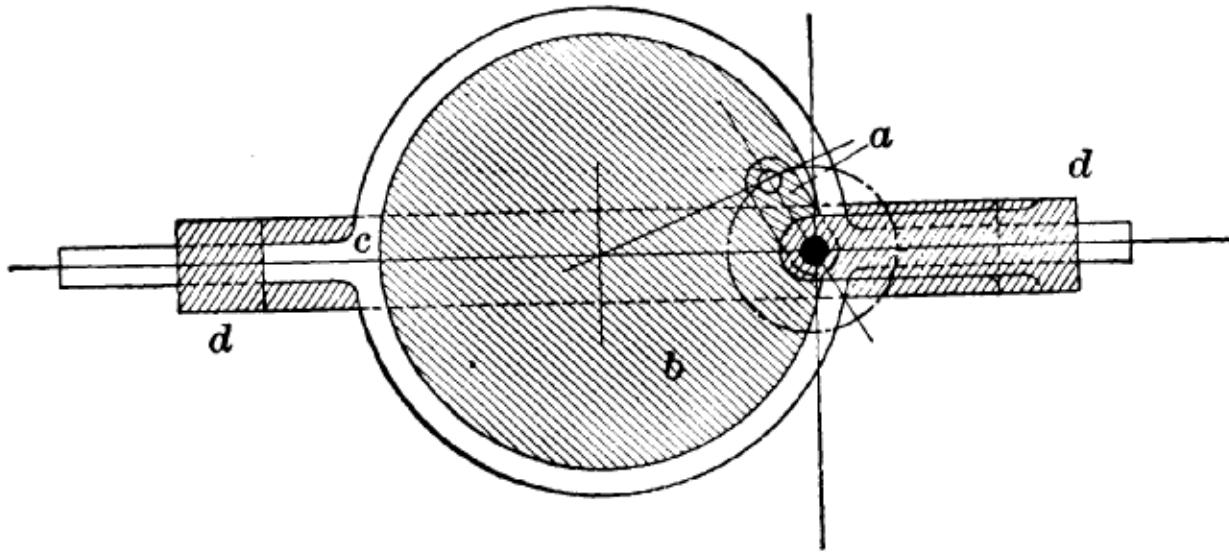

FIG. 108.

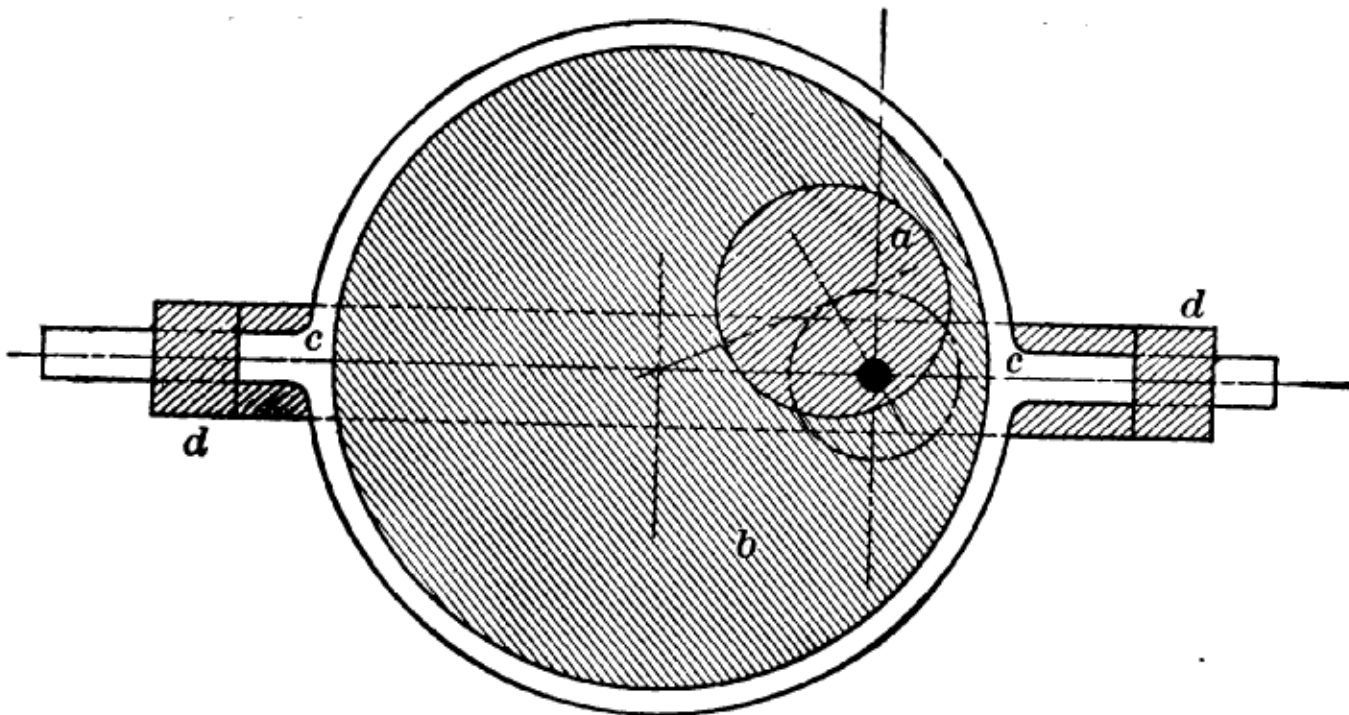

FIG. 109.

lesser degree. The links a and b have now both become eccentrics, while c takes the form of a strap provided with projections sliding in guides formed on d . The kinematic lengths, however, of the links in Fig. 108 are just the same as in Fig. 109, and the relative movements are the same.

Here we have instances of the expansion of the pairs of elements bc and ab .

55. Augmentation of Chains.—Many instances occur in which typical kinematic chains are apparently disguised by the introduction of additional links. Such a change is called by Reuleaux the *augmentation* of a chain or of a mechanism, and the links which are added, while giving the chain no new kinematic properties as a whole, are introduced for constructive reasons.

Take as an instance a bicycle wheel and its axle. Here the movement of the wheel relatively to the frame to which the axle is attached is exactly the same as if the connection between them were a simple turning pair. But on examination we find that the actual pairing is of quite a different character, and that a series of balls running in grooves cut in the hub of the wheel, and in the axle, have been provided, to minimize friction and wear.*

Some examples occur in which a relative motion that might have been attained by simple pairing is arrived at by the use of a whole chain, and such cases might equally well be looked upon as instances of augmentation.

A complex train of toothed wheels is often employed to give a velocity ratio which might have been obtained by a chain much simpler mechanically, but occupying more space, or inadmissible for some other reason. Again, in a steam-engine indicator the piston and rod are guided, not by a simple sliding pair, but by a straight-line motion, which is in itself a kinematic chain. Many other instances might be cited in which pairing is replaced by "chaining," that is, by the introduction of linkage; the link or links introduced being so arranged as not to alter any of the relative motions already existing.

It has been pointed out by Reuleaux that a chain which already possesses the largest number of links which it can

* See Fig. 225.

