

CHAPTER IX.

RATCHET MECHANISMS AND ESCAPEMENTS.

75. Ratchet-gearing.—We have so far considered mechanisms in which relative motion of the various links is possible at any instant, so that no link is definitely held or checked by another. We have now to study the action of *Ratchet-gearing*, which may be said to be gearing so arranged that certain links are temporarily or periodically locked together or connected during the action of the mechanism. This locking or checking of relative motion may be so effected that relative motion of the two links is only possible in one sense or direction (when the gear is called by Reuleaux a *Running-ratchet Train*), or movement in both directions may be rendered impossible when the ratchet acts, in which case the gear is known as a *Stationary-ratchet Train*. Fig. 150 shows the two kinds of ratchet-train in their typical

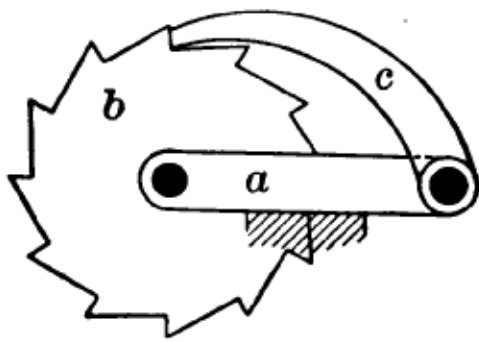

Running.

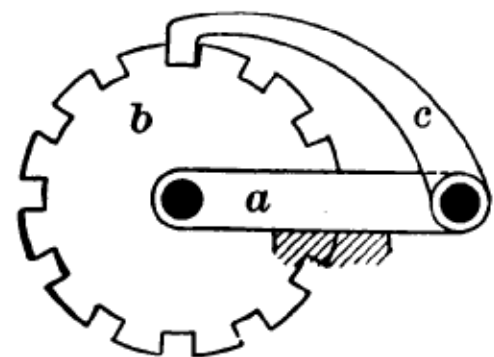

Stationary.

FIG. 150.

forms. Each consists of a frame or arm *a*, a ratchet-wheel *b*, and a ratchet or click *c*. In the first figure *b* is evidently capable of left-handed rotation only, so long as the ratchet *c* (sometimes called a *pawl*) is resting against its teeth. In the second figure motion is only possible when the pawl is

lifted clear. Examples of simple ratchet-trains will readily occur to the reader; in Fig. 151, for instance, is shown the

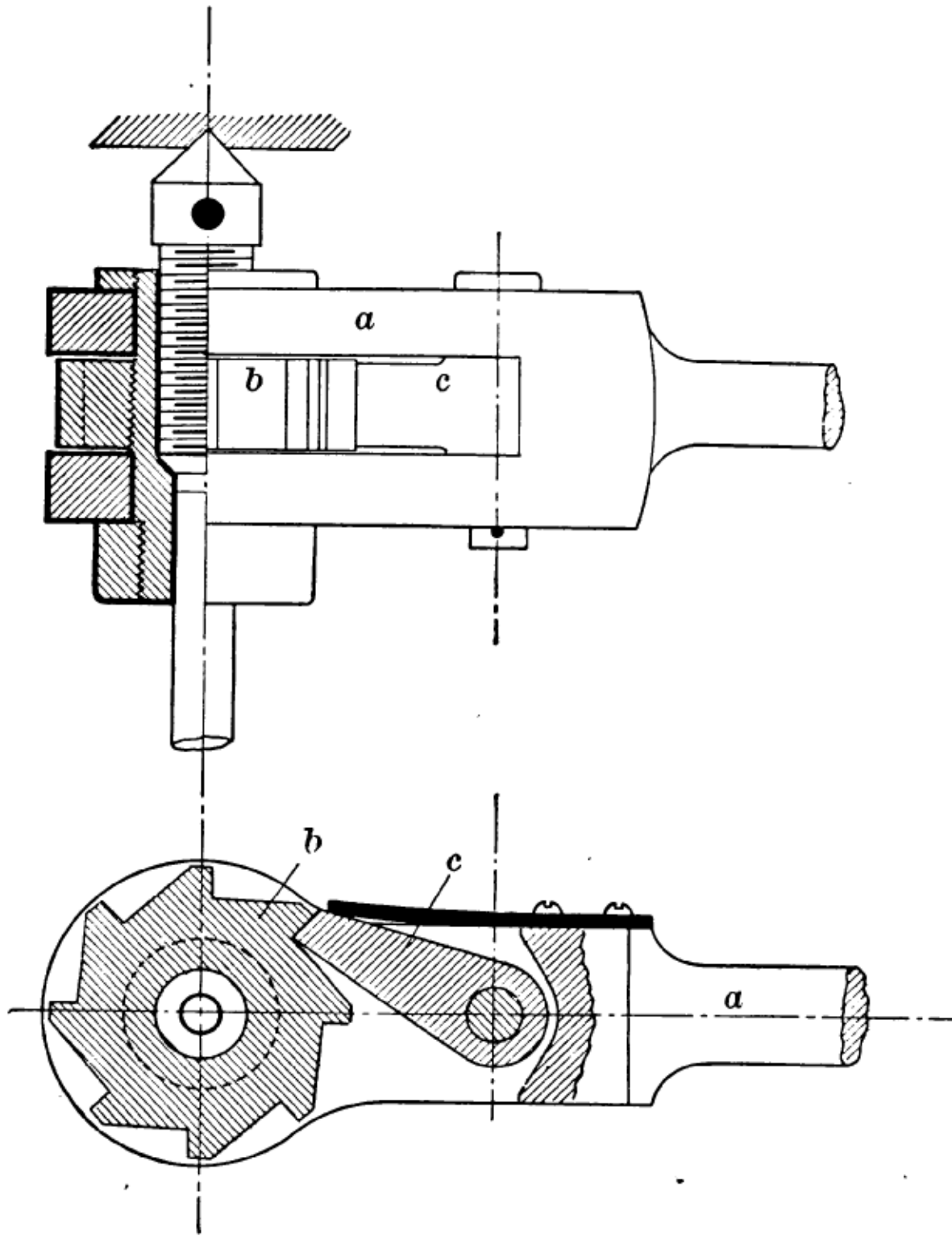

FIG. 151.

mechanism of a ratchet-drill, in which the different links are lettered in the same way as in the preceding figure.

76. Running Ratchets.—It is not necessary that the connection between the pawl and ratchet-wheel in a running ratchet should be of the positive kind shown above. Fig. 152 shows a form of frictional ratchet gear commonly used to transmit motion in one sense only from the crank-axle to the sprocket-wheel of a "free-wheel" bicycle. Here the ratchets themselves, *cc*, take the form of small rollers held up

by springs behind them; the rollers are confined within a driving-ring, *b*, attached to the sprocket-wheel, and when in action jam between this ring and suitably formed surfaces on a ratchet-wheel, *a*, attached to the crank-axle. Such

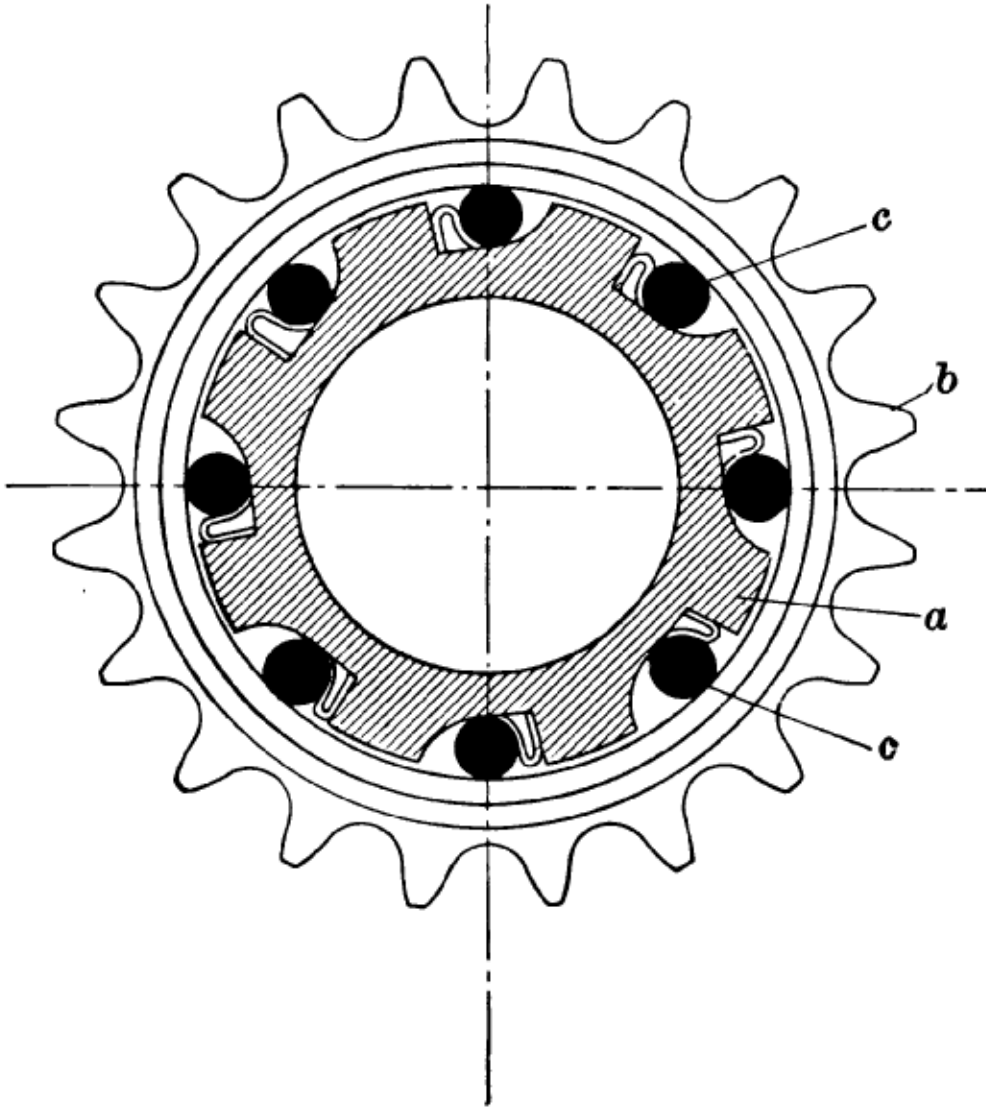

FIG. 152.

frictional ratchet gears are sometimes classed under the head of *silent ratchets*.

It should be noted that while ratchet-trains are used most frequently for controlling the motion of a turning pair, there are many cases in which such trains actuate links which have linear motion.

Fig. 153 shows a running-ratchet gear in which the ratchet *c*, attached to a reciprocating bar *d*, acts on a ratchet-rack *b*, and drives it in one direction only, motion in the opposite direction being prevented by a second ratchet or pawl *c'*, attached to the fixed link *a*. The mechanism is thus a combination of two running-ratchet trains, *abcd* and *abc'*; the former for driving, the latter for checking.

Most running ratchets in common use are really a combination of this kind; for example, in the ratchet-drill the function of the checking ratchet is performed by the frictional resistance of the drill in its hole.

It is important to note that the form of the surfaces on which the pawl and ratchet-wheel or rack engage must be carefully chosen, in order that the mechanism may fulfil its purpose. The shape of the pawl must in fact be such that the pressure between it and the tooth or surface with which it acts does not tend to throw it out of gear. Further, the mechanism must be force-closed, so that the pawl always tends to engage itself; this is commonly effected either by the action of springs (Figs. 151 and 152), or by the weight of the pawl itself (Figs. 150 and 153), or, in some cases, by making the pawl itself a spring. Fig. 154 shows a running friction ratchet which depends for its action on the weight of the ring-shaped pawl itself. Such a mechanism has been employed in certain electric arc lamps for controlling the downward movement of the carbons.

77. Stationary (Checking and Releasing) Ratchets. — Ratchet mechanisms of this type are used where it is necessary to check and release the driven link at will. In most cases a running ratchet or a cam is provided for the purpose of actuating the link whose motion is controlled by the locking ratchet. The mechanism of a *lever-lock* (shown diagrammatically in Fig. 155) is of this kind. The tumbler *c* and the bolt *b* here form a stationary-ratchet mechanism with the frame *a*.

The release of the bolt is effected by the action of the portion *M* of the key, which really forms a cam engaging with the curved surface of the profile *PQ* of the tumbler. When this release has been effected the bolt is shot back by the action of the portion *N* of the key. This part (also a cam) moves the bolt by engaging with the notch seen on the under side of the bolt. In actual lever-locks three, four, or more tumblers are used, with a corresponding number of steps on

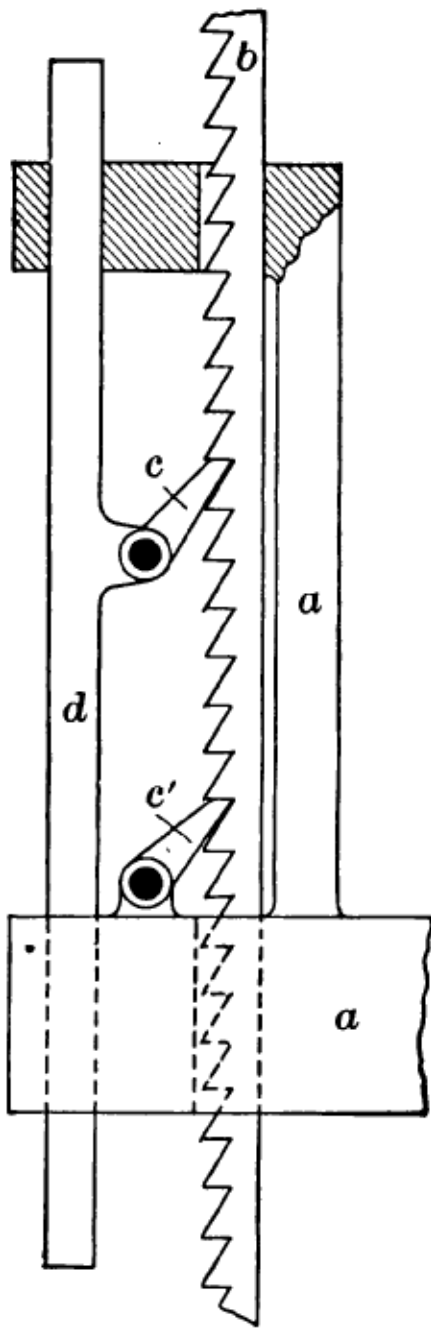

FIG. 153.

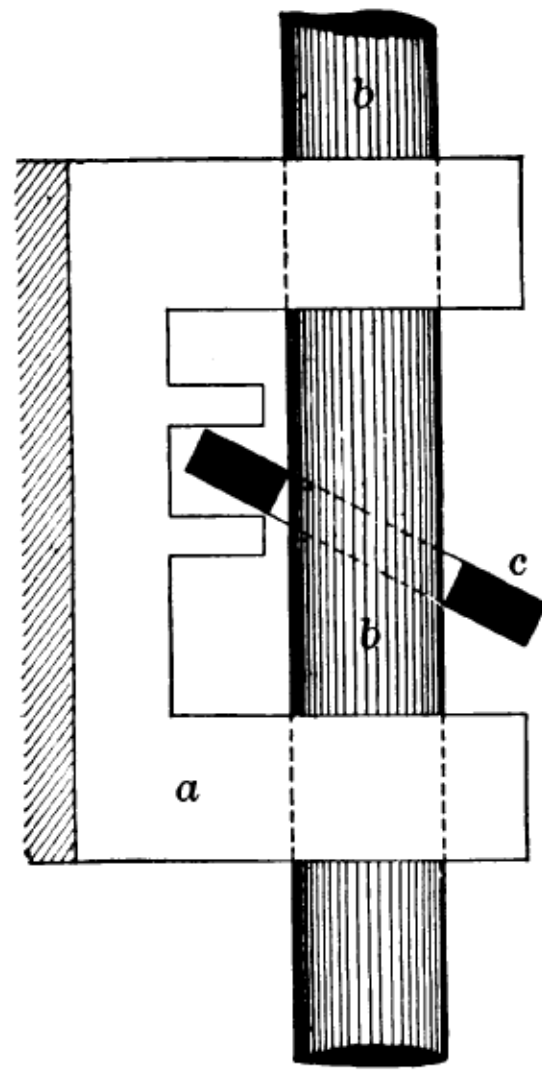

FIG. 154.

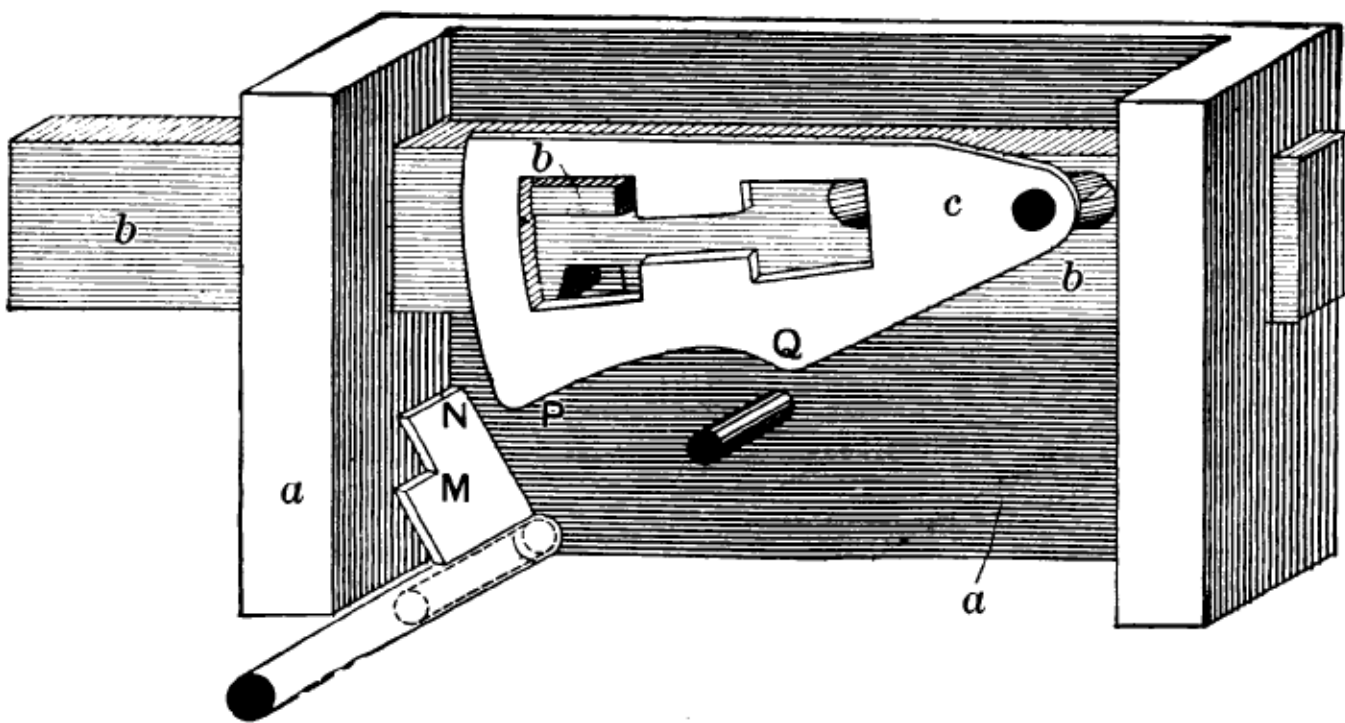

FIG. 155.

the key, and springs are provided so as to press the tumblers against the key.

Releasing and checking ratchets need not necessarily be positive in their action; they may depend on frictional forces just as in the case of the driving ratchet of Fig. 152. Thus, for example, a friction-brake may be looked upon as a frictional checking ratchet.

In Figs. 156a and 156b we have another example of a checking-ratchet train, in the case of the *Yale lock*. This

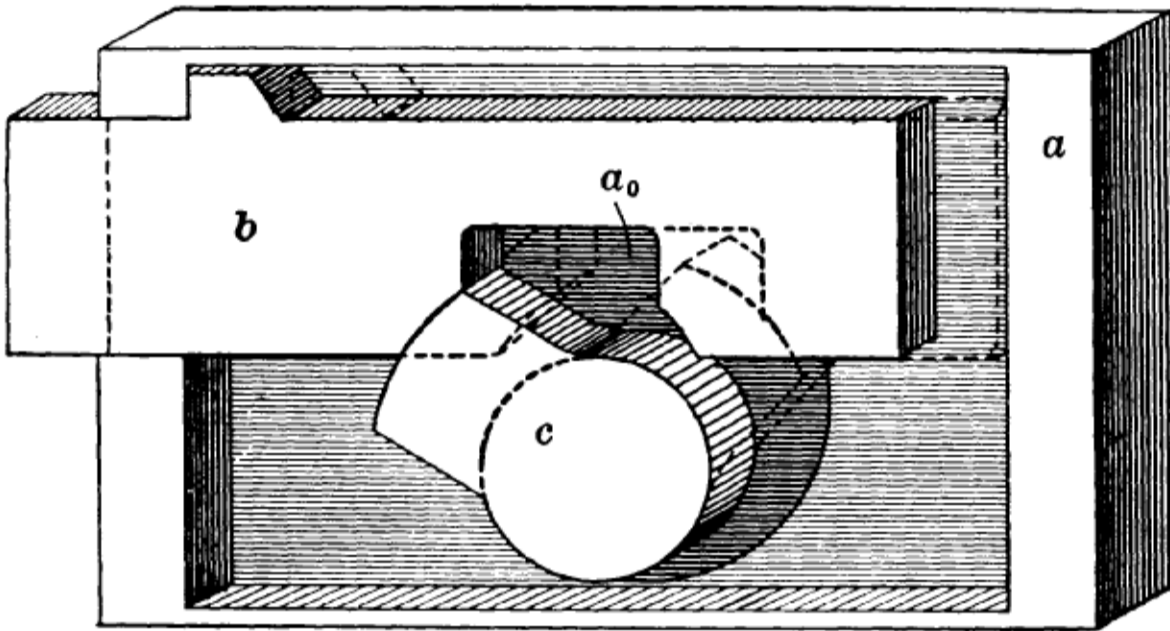

FIG. 156a.

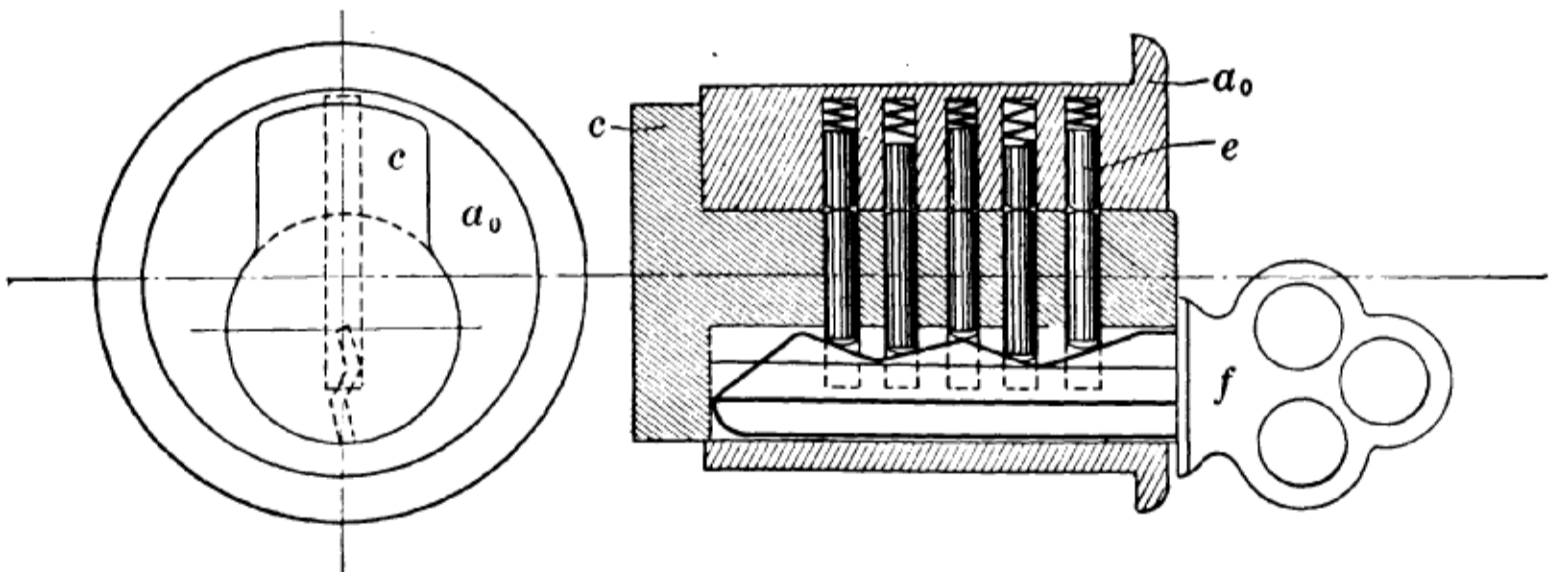

FIG. 156b.

lock really contains two distinct mechanisms, one a cam-train abc , which actuates the bolt, and the other a locking-ratchet train, which secures the cam, and can only be released by the insertion of the correct form of key. These mechanisms are shown separately. Fig. 156a shows the

